

Revision History

Rev	Description	Date	Approved
D	New Drawing & OEM No.	22/03/22	JB

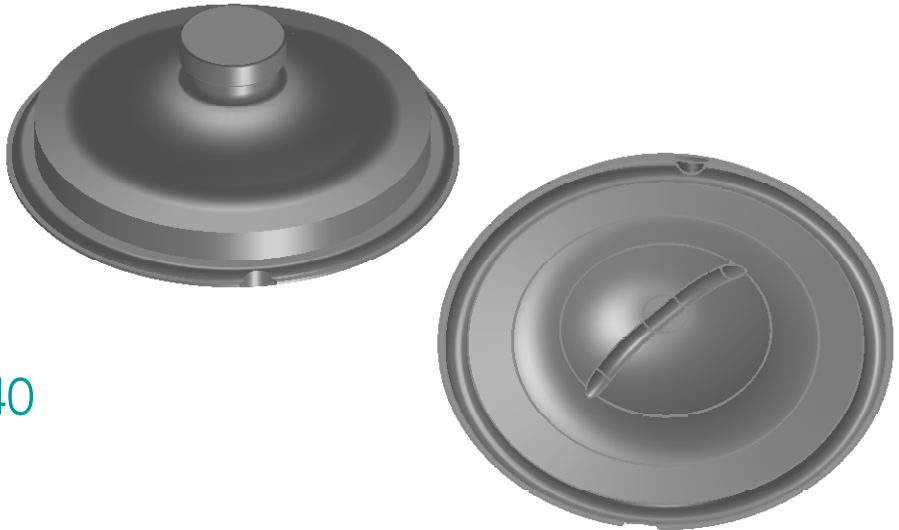
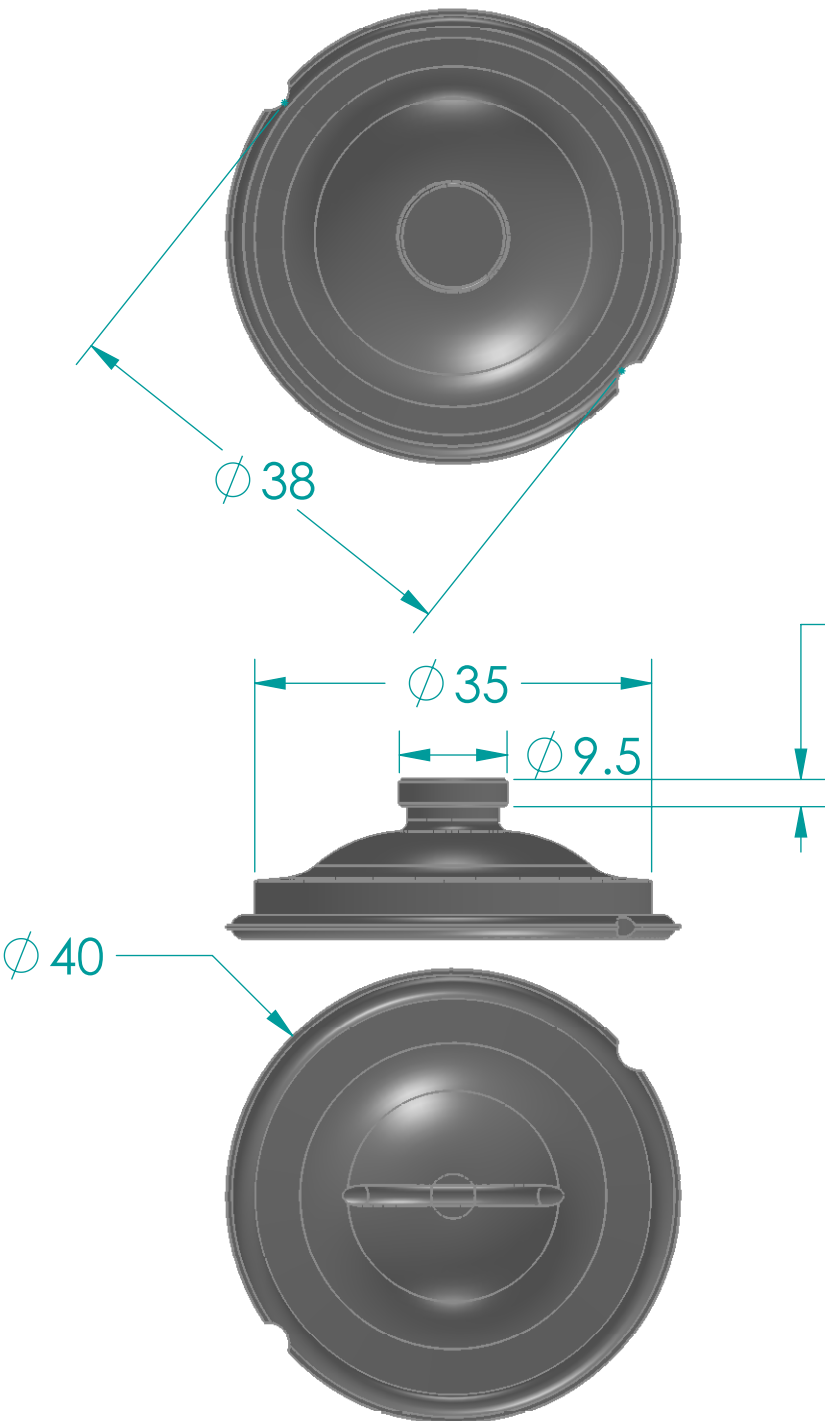

Replacement Diaphragm for:-
 OEM PART NUMBER = DA010E2
 USED ON 3/8" (DN10) Diaphragm Valve

	Name	Date	
Drawn	M.Mc Keon	19/12/21	
Checked			
Material - EPDM Complies with CFR 177.2600 and Conforms to USP Class VI Biological Reactivity Tests Section #87 and #88			TITLE DD02-SE7R
Size A	FOOT PRINT DIMENSIONS		Rev D
File: DD02-SE7R-RevD			
SCALE: 3:2 mm	Job: 24	Sheet 1 of 1	

Disclaimer - Diaphragm Direct® does not manufacture, represent, nor sell OEM valves or diaphragms manufactured by any other company. Diaphragm Direct® brand diaphragms are not sponsored by any other manufacturers. Any name, model, part number, brand, image, material or referral is for descriptive purposes only. Diaphragm Direct® brand replacement diaphragms are guaranteed to fit OEM equipment and meet or exceed OEM specifications. Diaphragm Direct® brand replacement diaphragms are covered by the standard Diaphragm Direct® limited product warranty.